

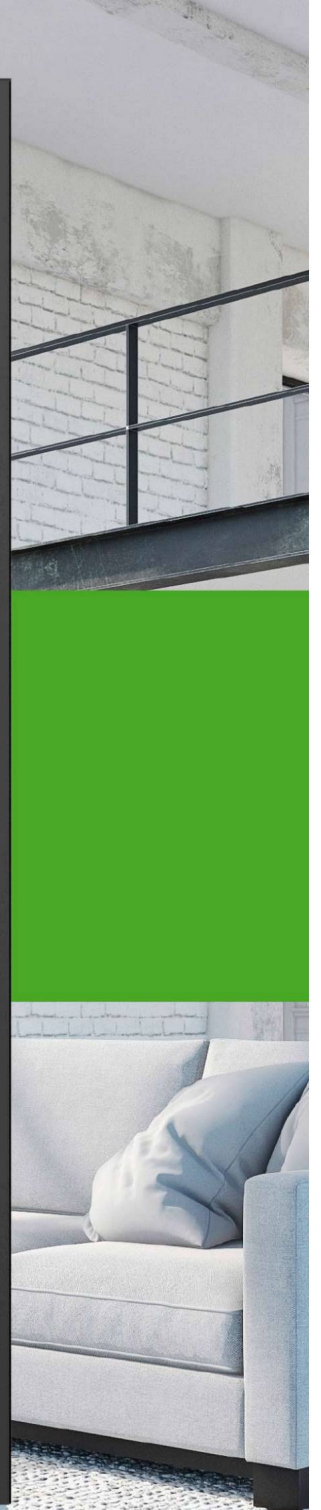

PASSIVEDORS

PUERTAS DE ALUMINIO DE CALIDAD



PASSIVE DOORS

Nuestra I+D ha desarrollado una línea de puertas con los mejores sistemas de seguridad y con aislamientos que proporcionan resultados térmicos inmejorables.

Gran versatilidad, pudiendo ser instaladas tanto en el interior como en el exterior de las viviendas.

Todo esto proporciona un producto de Calidad y gran durabilidad.

Our I+D has developed a line of doors with the best security systems and with insulation that provide unbeatable thermal results.

Great versatility, being able to be installed both inside and outside the homes.

All this provides a product of quality and great durability.

Notre société I+D a développé une gamme de portes avec les meilleurs systèmes de sécurité et une isolation offrant des résultats thermiques imbattables.

Grande polyvalence, pouvant être installé à l'intérieur et à l'extérieur des maisons.

Tout cela offre un produit de qualité et une grande durabilité.



Detalle del marco en aluminio
Detail of the aluminum frame
Détail du cadre en aluminium



SISTEMAS

SYSTEMS / SYSTÈMES

Las puertas PASSIVE DOORS están contruidas mediante perfiles de aluminio con 3 sistemas diferentes.

PASSIVE DOORS doors are built using aluminum profiles with 3 different systems.

Les portes PASSIVE des portes sont construites en utilisant des profilés en aluminium avec 3 systèmes différents.



Sistema de puerta standarizada con 2 modelos lisos y 2 con vidrio.

- Solo 1 hoja.
- Color blanco txt y gris 7016 txt (personalizable a partir de 10 uds.).
- Marco de aluminio con RPT
- Hoja de aluminio con RPT compuesta de chapa de aluminio interior/externo de 1.5 mm de espesor y núcleo de poliestireno expandido de alta densidad.
- 2 Bisagras antipalanca.
- Maneta inox y tirador inox redondo de 400 mm.
- Cerradura de seguridad 3 puntos con 5 llaves de seguridad

Standardized door system with 2 smooth models and 2 with glass.

- One leaf door
- White color...and grey (customizable from 10 units)
- Aluminium frame with rpt
- Aluminium sheet made of aluminium inside an outside and nucleus of high density expanded polystyrene
- 2 hinge antilever
- Inox handle and round inox door handle of 400mm
- 3-point security lock with 5 security keys

Système de porte standardisé avec 2 modèles lisses et 2 avec verre.

- Un seul ouvrant
- Couleur blanc txt et gris 7016 txt (personnalisable à partir de 10 unités.).
- Dormant en aluminium avec RPT
- Ouvrant en aluminium avec RPT composé avec un panneau aluminium intérieur/extérieur de 1.5 mm d'épaisseur et âme isolante en polystyrène de haute densité.
- 2 paumelles anti-dégondage.
- Poignée inox y bâton de maréchal inox rond de 400 mm.
- Fermeture de sécurité 3 points con 5 clés de sécurité

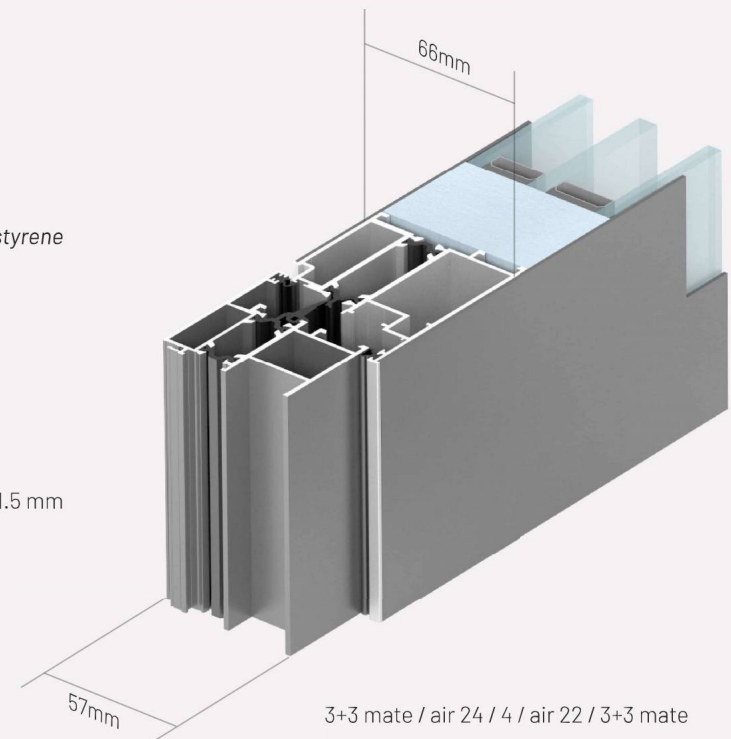

PLUS DOOR PL

Sistema de puerta a medida con todos los modelos

- Solo 1 hoja y opcional fijos.
- Fabricación a medida.
- Altura máxima de 2300mm.
- Todos los colores.
- Marco de aluminio con RPT
- Hoja de aluminio con RPT compuesta de chapa de aluminio interior/externo de 1.5 mm de espesor y núcleo compuesto de tablero de chopo 8mm + poliestireno expandido de alta densidad + tablero de chopo 8mm.
- 3 Bisagras antipalanca y maneta inox rectangular y tirador rectangular inox de 500 mm.
- Cerradura de seguridad 3 puntos automatica (opc. 4 puntos y 7 puntos) con 5 llaves de seguridad.
- Opcional motorización/domótica.

Customized door system with all models

- One leaf door optional fixed
- Custom made
- Maximum height of 2300mm
- All colours
- Aluminium frame with rpt
- Aluminium sheet made of aluminium inside an outside and nucleus of poplar board and 8mm high density Expanded polystyrene
- 3- antilever hinge , handle and rectangular inox door handle of 500 mm
- 3-point automatic security lock with 5 security keys (optional 4 and 7 points)
- Optional engine/ domotic

Système de porte sur mesure avec tous les modèles

- Un seul ouvrant et fixes optionnels
- Fabrication sur mesure
- Hauteur maximum de 2300mm
- Toutes les couleurs
- Dormant en aluminium avec RPT
- Ouvrant en aluminium avec RPT composé avec un panneau aluminium intérieur/extérieur de 1.5 mm d'épaisseur et âme isolante en polyesthirène de haute densité et panneau de peuplier de 8mm
- 3 paumelles anti-dégondage et poignée inox rectangulaire et bâton de maréchal rectangulaire inox de 500mm
- Fermeture de sécurité 3 pointys automatique(option 4 points y 7 points)avec 5 clés de sécurité
- Option motorisation/domotique

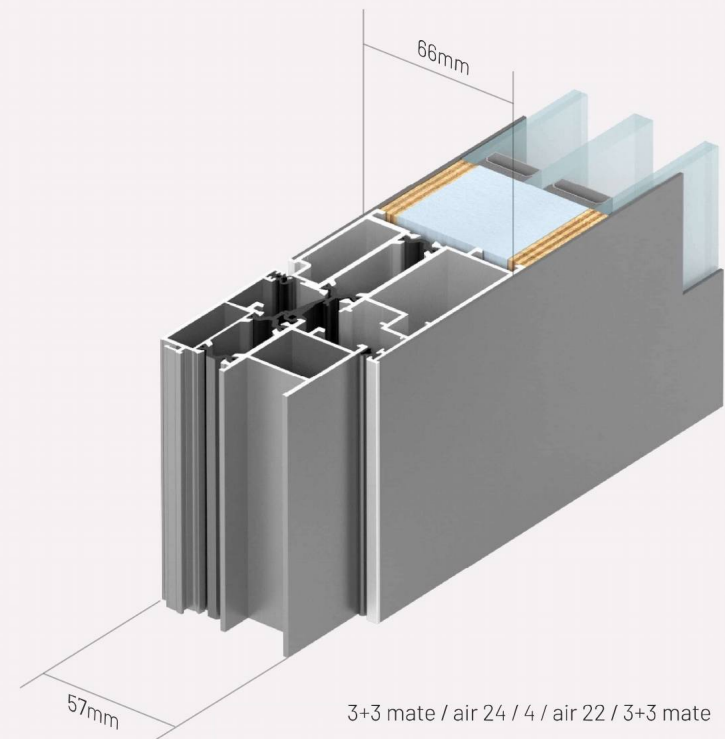

PREMIUM DOOR PR

Sistema de puerta a medida con todos los modelos

- 1 y 2 hojas, y opcional fijos.
- Fabricación a medida.
- Altura máxima de 2300mm bisagra oculta y 2700mm vista.
- Todos los colores.
- Hoja de aluminio con RPT compuesta de chapa de aluminio interior/exterior de 1.5 mm de espesor y núcleo compuesto de tablero de chopo 8mm +poliestireno expandido de alta densidad + tablero de chopo 8mm.
- Bisagras ocultas y manetas Inox rectangular y tirador inox rectangular de 1800 mm.
- Cerradura de seguridad 4 puntos automática (opc. 7 puntos) con 5 llaves de seguridad.
- Opcional motorización/domótica.

Customized door system with all models

- One or two leaf door
- Custom made
- Maximum height 2300 mm with hidden hinge and 2700mm with normal hinge all colours
- Aluminium sheet made of aluminium inside an outside and nucleus of poplar board and 8 mm high density expanded polystyrene
- Hidden hinged , inox handle and rectangular inox door handle of 1800 mm
- 4-point automatic security lock with 5 security keys (optional 7 points)
- Optional engine/ domotic

Système de porte sur mesure avec tous les modèles

- 1 et 2 ouvrants, et fixes optionnels.
- Fabrication su mesure
- Hauteur maximum de 2300mm, paumelles cachées et 2700mm vue
- Toutes les couleurs.
- Ouvrant en aluminium avec RPT composé avec un panneau aluminium intérieur/extérieur de 1.5 mm d'épaisseur et âme isolante en polyesthirène de haute densité et panneau de peuplier de 8mm.
- paumelles cachées et poignée inox rectangulaire de bâton de maréchal rectangulaire de 1800mm
- Fermeture de sécurité 4 points automatique (option. 7 points) avec 5 clés de sécurité.
- Option motorisation/domotique

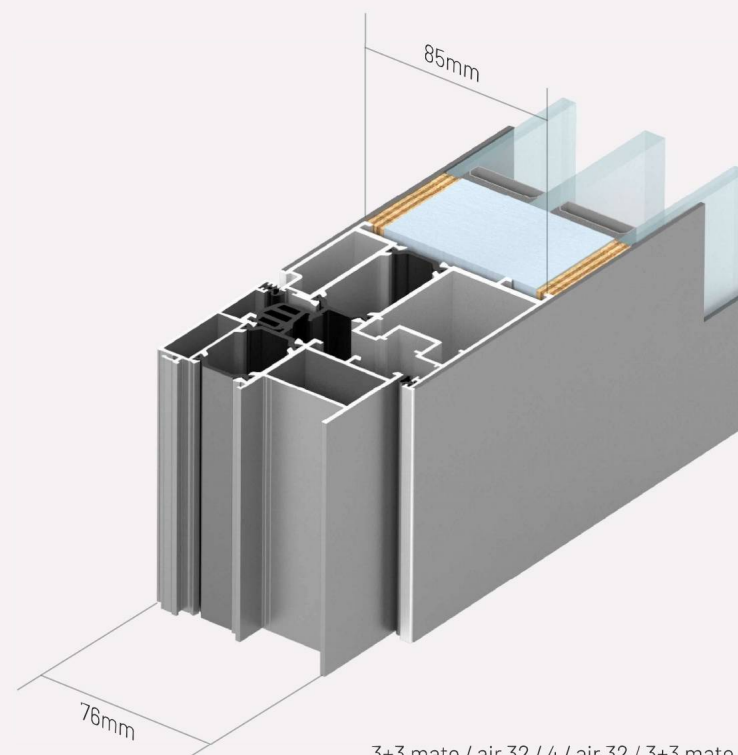

3+3 mate / air 32 / 4 / air 32 / 3+3 mate

SISTEMA DE LLAVE

KEY SYSTEM / SYSTÈME DE CLÉ

Ventajas del producto:

- Bombillo seguridad mod. hs-10 55-35 mm.
- Resistente al bumping, doble embrague.
- Doble varilla de acero antitaladro, antiganzuable.
- Ranuras exteriores para evitar manipulaciones externas.

Product advantages:

- Security lock cylinder mod. hs-10 55 - 35 mm.
- Anti-Bump, double clutch.
- Double steel anti-drill, pick resistant.
- External slots to avoid external manipulation.

Avantages du produit:

- *Cylindre sécurité mod. hs-10 55-35 mm.*
- *Résistant à la supplantation, double embrayage.*
- *Double vis à oeillet ouvert en acier anti-perçage, anticrochetage.*
- *Rainures externes pour empêcher la manipulation externe.*



ECO

PL

Ventajas del producto:

- Elevada comodidad de cierre.
- Protección de serie contra robos por impacto.
- Llave protegida por patente.
- La innovadora cavidad del pasador de la llave en los cilindros del sistema livius SL ofrece una segura protección anticopia.
- Protección contra taladrado y arrancado para evitar la apertura violenta.

PR

Product advantages:

- High closing comfort.
- Protection of series against robberies by impact.
- Key protected by patent.
- The innovative cavity of the pin of the key in the cylinders of the livius SL system offers a safe copy protection.
- Protection against drilling and ripping to avoid violent opening.

Avantages du produit:

- *Haut confort de fermeture.*
- *Protection des séries contre les vols par impact.*
- *Clé protégée par brevet.*
- *La cavité innovante de la broche de la clé dans les cylindres du système livius SL offre une protection sûre contre la copie.*
- *Protection contre le forage et le déchirement pour éviter une ouverture violente.*



DIN
EN 1303

DIN
18252

SKG



Pat.
2024

HS

F



ECO DOOR ECO



PLUS DOOR PL PREMIUM DOOR PR



COMBINACIONES

COMBINATIONS / DES COMBINAISONS

1 hoja / 1 sheet / 1 feuille



1 hojas + fijos / 1 sheet + fixeds / 1 feuille + fixes



Doble hoja / double sheet / double feuille



MODELOS DE PUERTAS

DOOR MODELS / MODÈLES DE PORTE

Utilizando las últimas tecnologías hemos desarrollado una línea de puertas adaptadas al mercado actual teniendo en cuenta las tendencias más modernas y los diseños más innovadores.

Using the latest technologies we have developed a line of doors adapted to the current market taking into account the most modern trends and the most innovative designs.

En utilisant les dernières technologies, nous avons développé une ligne de portes adaptée au marché actuel en tenant compte des tendances les plus modernes et des designs les plus innovants.

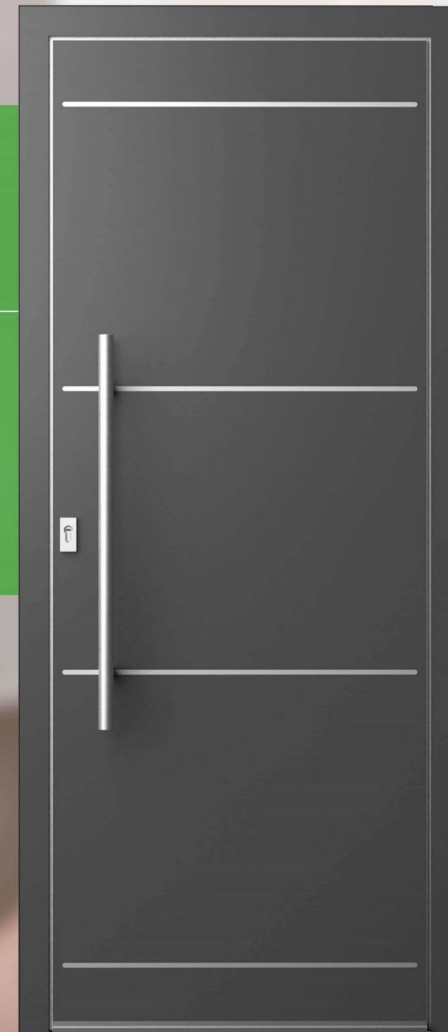

MOD.01



RAL 9016 txt

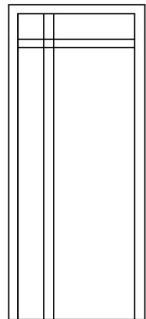

MOD.02



RAL 7016 txt

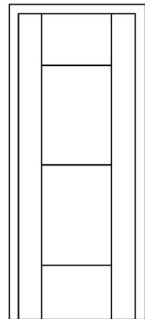

MOD.03



RAL 7016 txt

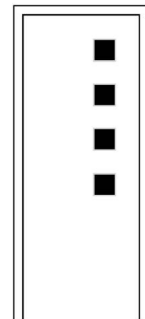

MOD.04



RAL 9016 txt

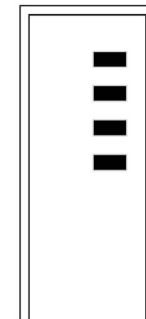

MOD.05



Sable 2100 txt

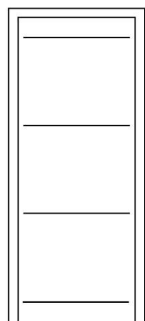

MOD.06



RAL 7022 txt

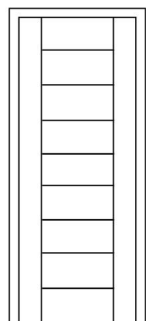

MOD.07



RAL 6009 txt

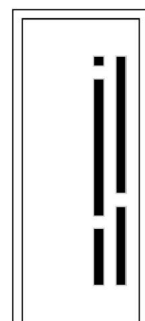

MOD.08



Acero Corten txt

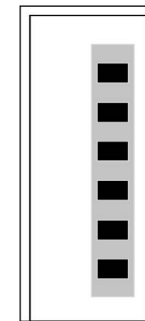

MOD.09



RAL 9016 txt

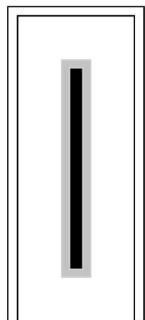

MOD.10



RAL 7022 txt

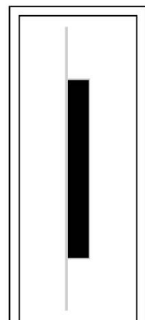

MOD.11



Oxido txt

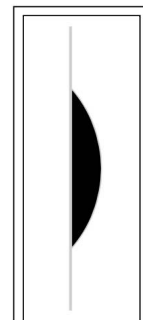

MOD.12



RAL 9005 txt

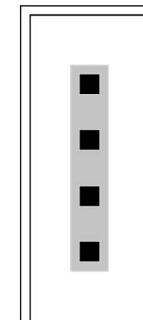

MOD.13



FORMENTERA

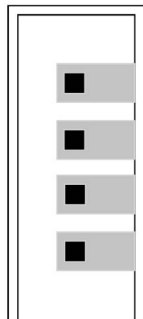

MOD.14



RAL 9016 txt

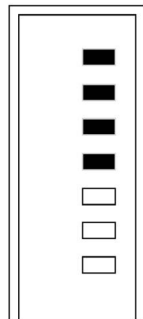

MOD.15



RAL 6009 txt

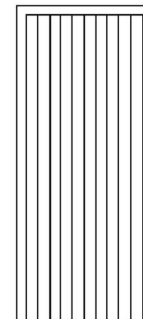

MOD.16



RAL 7022 txt

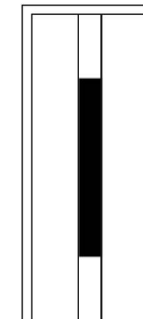

MOD.17



RAL 7016 txt

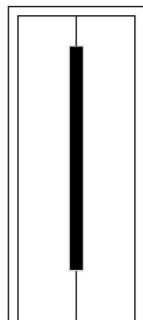

MOD.18



RAL 8014 txt

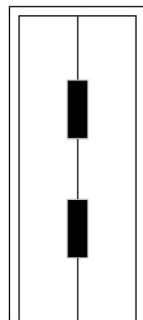

MOD.19



RAL 7022 txt

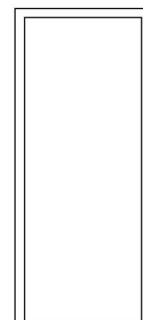

ACCESORIOS

ACCESSORIES / ACCESSOIRES

Hemos creado una línea de accesorios que pueden ser combinados en los sistemas PLUS DOOR y PREMIUM DOOR permitiendo personalizar el producto final al gusto del cliente.

Todos los accesorios utilizados son de acero inoxidable de primeras marcas obteniendo una gran calidad en los acabados y un funcionamiento duradero.

We have created a line of accessories that can be combined in the PLUS DOOR and PREMIUM DOOR systems allowing to customize the final product to the client's taste.

All the accessories used are stainless steel, of first brands obtaining a high quality in the finishes and a lasting operation.

Nous avons créé une gamme d'accessoires pouvant être combinés dans les systèmes PLUS DOOR et PREMIUM DOOR permettant de personnaliser le produit final selon les goûts du client.

Tous les accessoires utilisés sont en acier inoxydable des premières marques obtenant une haute qualité dans les finitions et une opération durable.



Ref. MAN-EC-01

ECO



Ref. BO-EC-01

ECO



Ref. TIR-EP-01

400mm ECO 400-1000mm PL PR ECO



Ref. PO-EC-01

ECO



Ref. MAN-EC-02

PL PR



Ref. BO-EC-02

PL PR



Ref. TIR-EP-02

500mm-1800mm PL PR

Controles de acceso domóticos / Home automation access controls / Contrôles d'accès domotique



Ref. ACC-EP-01

PL PR



Ref. ACC-EP-02

PL PR



Ref. ACC-EP-03

PL PR



Ref. ACC-EP-04

PL PR

CERRADURAS

LOCKS / LES SERRURES

La gama de cerraduras proporcionan un alto grado de seguridad en todo momento. Todas las cerraduras llevan sistemas de bloqueo de tres puntos con opción a mejorar a cuatro o seis puntos. Opcionalmente en los modelos PLUS DOOR y PREMIUM DOOR se podrán automatizar con un avanzado sistema de apertura con huella digital, teclado numérico, mando a distancia o apertura vía telefónica.

The range of locks provide a high degree of security at all times. All locks have three-point locking systems with the option to improve to four or six points. Optionally, the PLUS DOOR and PREMIUM DOOR models can be automated with an advanced opening system with fingerprint, numeric keypad, remote control or telephone opening.

La gamme de serrures offre un haut degré de sécurité à tout moment. Tous les verrous ont des systèmes de verrouillage à trois points avec la possibilité d'améliorer à quatre ou six points. En option, les modèles PLUS DOOR et PREMIUM DOOR peuvent être automatisés avec un système d'ouverture avancé avec empreinte digitale, pavé numérique, télécommande ou ouverture de téléphone.

EUROPA 3 puntos / points / points
ref. CER-00-03



AUTOMATIC 3 puntos / points / points
ref. CER-AUT-00-03



AUTOMATIC 4 puntos / points / points
ref. CER-AUT-00-04



AUTOMATIC 7 puntos / points / points
ref. CER-AUT-00-07





ACABADOS

FINISHES / FINIT

Todos los colores utilizados en los tres sistemas están avalados por certificados de calidad, con una gama de colores pensada para espacios modernos y funcionales.

All the colors used in the three systems are guaranteed by certificates of quality, with a range of colors designed for modern and functional spaces.

Toutes les couleurs utilisées dans les trois systèmes sont garanties par des certificats de qualité, avec une gamme de couleurs conçues pour des espaces modernes et fonctionnels.

Colores RAL texturizados

Textured RAL colors

Couleurs RAL texturées



RAL
9016TXT



RAL
9005TXT



RAL
8014TXT



RAL
7022TXT



RAL
7016TXT



RAL
6009TXT



RAL
1015TXT

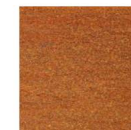

RAL
OXIDO TXT



RAL
3005TXT



Sable
2100TXT

Lacados decorativos

Decorative lacquers

Laques décoratives



CEDRO
TXT



ROBLE
RÚSTICO
TXT



PINO
ENVEJECIDO
TXT



TEKA
TXT



NOGAL
OSCURO
TXT



EMBERO
TXT



ROBLE
GOLDEN
TXT



FORMENTERA
TXT



ALASKAN
TXT



ACERO
CORTEN
TXT

* Los colores y acabados de este catálogo pueden no parecerse a la realidad debido a la impresión del mismo, consulte con las muestras reales de su fabricante.

* The colors and finishes of this catalog may not resemble the reality due to the printing of the same, check with the actual samples of its manufacturer.

* Les couleurs et les finitions de ce catalogue peuvent ne pas ressembler à la réalité à cause de l'impression de celui-ci, vérifiez avec les échantillons réels de son fabricant.

PASSIVED  **RS**
PUERTAS DE ALUMINIO DE CALIDAD

Distribuido por / Distributed by / Distribué par:

 **Herrajes Europeos**
www.herrajeseuropeos.com

